

PALAVA'S FINEST NEIGHBOURHOOD



City Office: Palava Experience Centre, Near Lodha World School, Kalyan-Shil Road, Palava.
Corporate Office: Lodha Excelus, N.M. Joshi Marg, Mahalaxmi, Mumbai - 400 011.

Disclaimer:

* Located adjacent to Palava.

Not available in all apartments, Exceptions apply.

¹ Or equivalent.

³ Except kitchen, bathrooms and utility/service/servant areas.

Disclaimer: Conditions apply. The plans, layout, specifications, images and other details herein are indicative and the developer/owner reserves the right to change any or all of these in the interest of the development. Select fittings/options may be available in limited units only or available at additional price and are not part of the standard unit. All brands mentioned herein maybe replaced by equivalent or better brand(s) as decided by the project architect. The printed material does not constitute an offer and / or contract of any type between the developer / owner and the recipient; any sales / lease of any unit in this development shall be solely governed by the terms of the agreement for sale / lease entered into between the parties and no details mentioned in this printed material shall in any way govern such transaction. The dimensions and/or areas stated in the plans are measured on basis of unfinished surfaces using polyline method and do not reflect the reduction in dimensions on account of the finishes being installed. Further, variance of +/-2% in the unit carpet area and/or unfinished dimensions is possible due to design and construction variances. Internal document for training and reference only. Not for circulation. Please verify calculations. Date of printing : June 17 | Exceptions apply.

Presenting
LAKESHORE GREENS



LAKESHORE PARK



INDIA'S NO. 1 SCHOOL



OLYMPIC SPORTS COMPLEX



BUSINESS DISTRICT



SHOPPING BOULEVARD

Over 28,000+ happy families.
GREAT LIFESTYLE. PROMISED & DELIVERED.



WELCOME TO PALAVA,
INDIA'S FASTEST
GROWING CITY.



Actual City Image

Waking up to birdsong, enjoying scenic views, living the privileged life in a world-class city - these are no longer dreams.

The living experience you have always wanted awaits you at Mumbai's sister city, Palava - designed to fulfill every dream and desire. Spread over 4500 acres and located close to the upcoming Navi Mumbai International Airport (via Taloja Bypass), Palava lies at the heart of the economic activity in the Mumbai Metropolitan Region (MMR). Palava is a short 20 minute drive from Thane, Navi Mumbai and Kalyan - and less than an hour's drive from South Mumbai via the Eastern Freeway.

Palava has been planned and designed by the world's smartest minds, for over half a decade - with the goal of offering the best residential, employment, business, academic and sports opportunities, along with international retail and leisure activities.

Palava is benchmarked to be amongst the top 50 most liveable cities in the world by 2025, and is set out to be everything a 21st century city ought to be.

In the last 6 years - 300% appreciation | 28,000+ homes purchased

WELCOME TO THE
FINEST NEIGHBOURHOOD
OF INDIA'S FASTEST
GROWING CITY.



The privileges of living at Lakeshore Greens:

When you live in the upscale neighbourhood of Lakeshore Greens, the wonders never cease. You have a mesmerizing lakefront on one side and Forest Greens* on the other. The Central Business District is just across the road and you can get to the Dombivali Badlapur road, and the Taloja road in a jiffy. While the most happening spots in the city – cafés and shopping on Central Avenue, and the iconic Centre for Arts and Culture – are but a short walk away. Waking up to birdsong, enjoying scenic views from your open-air deck, living the privileged life in a world-class city – these are no longer dreams.

- Two schools including India's no.1
- 6 Acre Lakeside Park
- Olympic sports complex
- Business district
- All amenities are at walking distance from residences

PALAVA TODAY. POISED TO TAKE OFF.



PALAVA TOMORROW. A WORLD CITY IN INDIA.



Spread across 4,500 acres, Palava is planned to perfection by the best urban designers in India. With over 18,000 homes delivered till date, Palava has not only promised a great lifestyle but also delivered it.

Located 20 minutes from the upcoming international airport in Navi Mumbai and a short drive from Thane and Kalyan is Palava, Mumbai's sister city which is poised to emerge as the top 50 most liveable cities in the world by 2025.

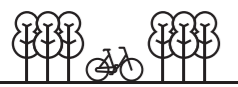

20,000+ TREES
WITH
60% OPEN SPACES



HOME TO
28,000+
FAMILIES



300% VALUE
APPRECIATION
IN 6 YEARS



INDIA'S FASTEST
GROWING CITY
WITH ANNUAL POPULATION
GROWTH OF MORE THAN 50%



AMONG TOP 50
MOST LIVEABLE CITIES



OVER
4 LAC
FAMILIES



OVER
3.5 LAC JOB
OPPORTUNITIES



OVER 2 LAC TREES
GIVING THE CLEANEST AIR AMONGST
TOP INDIAN CITIES



- ✦ Two ICSE schools operational with 3,000+ students
- ✦ International Standard sports facilities including a 9-hole golf course, a FIFA standard football ground, a cricket ground, a multi-sport arena and opportunities to get coached by professionals
- ✦ 5 lac sq.ft. mall with PVR multiplex, Big Bazaar and other shopping & dining options
- ✦ 1.3 km Riverside promenade with an amphitheatre to host cultural performances
- ✦ Luxurious clubhouses in every neighbourhood
- ✦ Dedicated shuttle buses to key locations in Thane, Mumbai and Navi Mumbai
- ✦ Smart City tie-up with IBM for 24x7 CCTV monitoring, e-governance, Palava Smart Card and much more



- ✦ Over 20 schools including India's no. 1 school
- ✦ Olympic sports complex where you can hone your sporting skills
- ✦ Walk to work and ensure that you spend maximum time with family
- ✦ Iconic centre for arts & culture that will play host to high-power performances
- ✦ World-class multi-disciplinary university to empower the future of India
- ✦ Central avenue with high-street retail and dining options
- ✦ Significant growth in rental and capital values

PALAVA, NESTLED IN PROSPERITY.

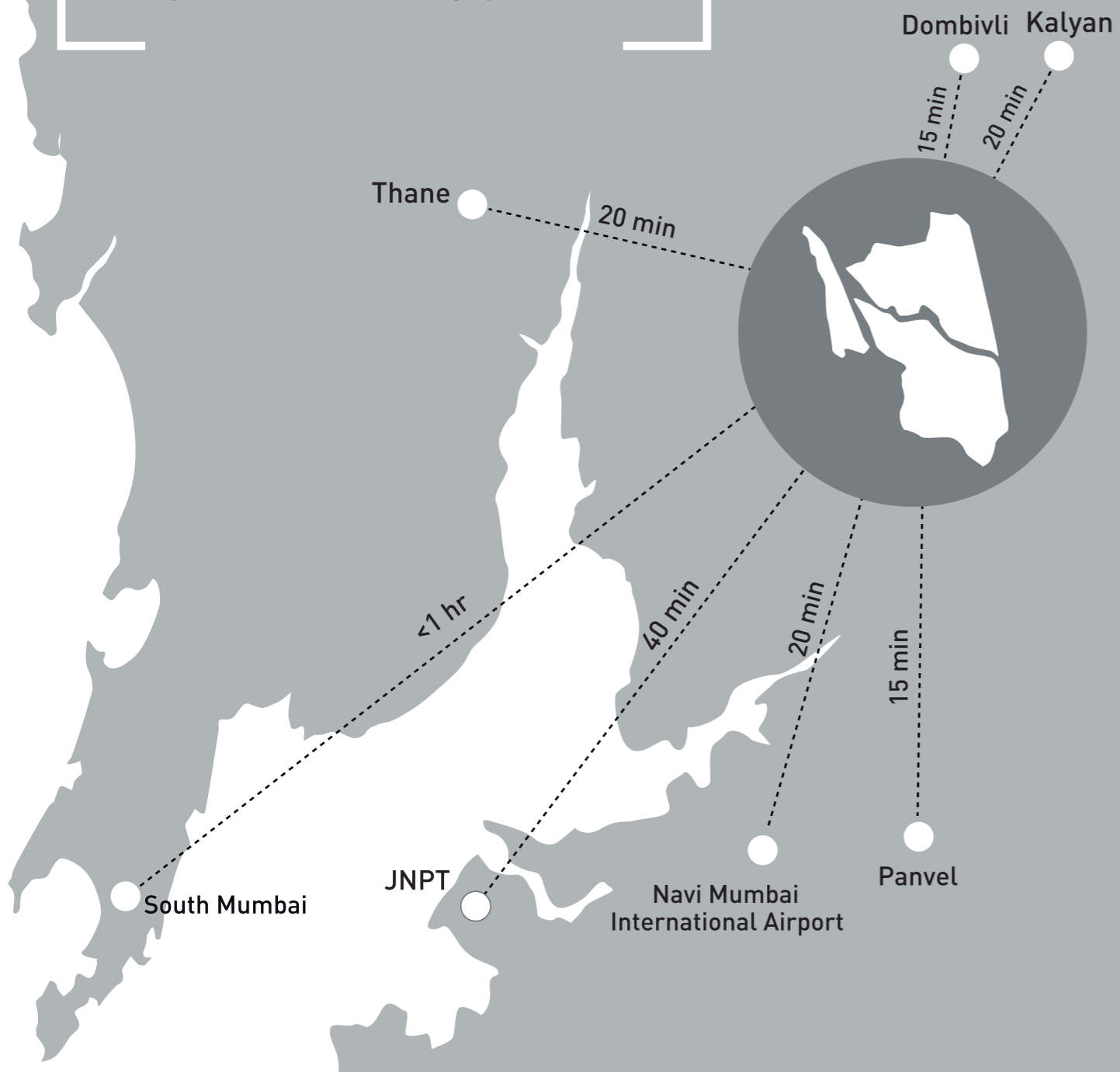

- Less than an hour from South Mumbai (via the Eastern Freeway)
- Planned expansion of roads leading to Vashi and Kalyan
- Well connected by rail. Nearby station include Dombivili (Central Line), Vashi (Harbour Line), and Diva (Vasai-Panvel Line)
- Upgradation of Diva station to prime junction in Central Line and approved new line to Navi Mumbai (Kalwa - Airoli)
- Within 20 minutes of the upcoming international airport
- Upcoming 450 acre MMRDA growth centre in the Palava region
- Corporate offices close to Palava: Accenture, Philips, Wipro, Cognizant, Capgemini, Dhirubhai Ambani Knowledge Park, Daily News & Analysis (DNA), Reliance Corporate Park, Reliance Jio, Godfrey Phillips, L&T Info Park

PALAVA CITY A GRAND VISION



WORLD-CLASS AMENITIES AT A WALKING DISTANCE



6 ACRE LAKESIDE PARK



CENTRAL AVENUE WITH HIGH-STREET RETAIL



WALK-TO-WORK BUSINESS DISTRICT



SHIVA TEMPLE



2 SCHOOLS INCLUDING INDIA'S NO. 1

Presenting
**LAKESHORE
GREENS**



OLYMPIC SPORTS COMPLEX



GRAND CLUBHOUSE



ICONIC CENTER FOR PERFORMING ARTS



CHILDREN'S MUSEUM





SCHOOL FOR MUSIC, DANCE & DRAMA

PROJECT PLANS

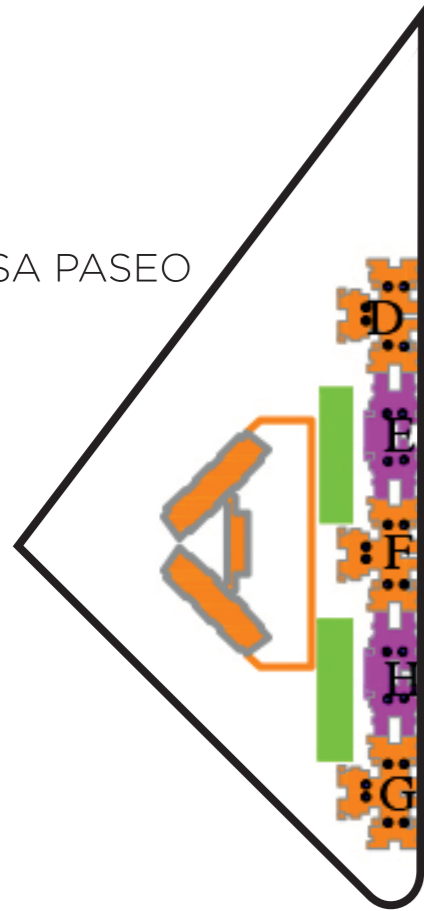
CASA PASEO



LEGEND

-  1 BHK
-  2 BHK OPTIMA
-  COURTYARD AROUND YOUR HOME WITH PLAY AREA, WALKWAY & SEATING AREA



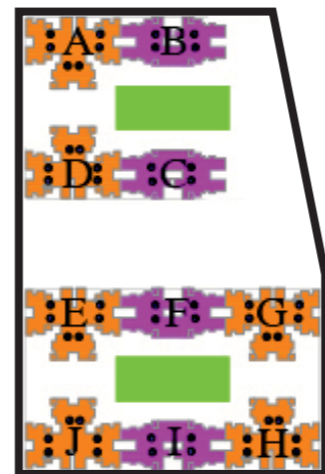

CASA PRIMIA

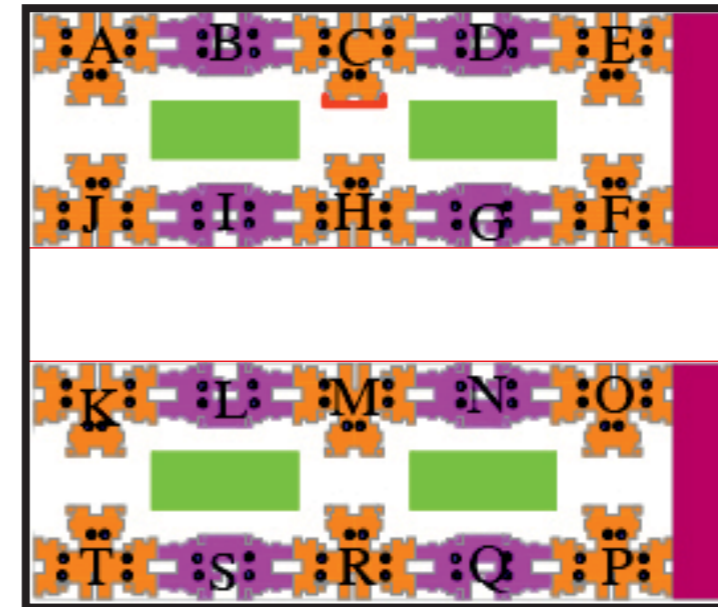

CASA ELITE



LEGEND

-  1 BHK
-  2 BHK OPTIMA
-  COURTYARD AROUND YOUR HOME WITH PLAY AREA, WALKWAY & SEATING AREA
-  HIGH - STREET SHOPPING & DINING

CASA REGALIA

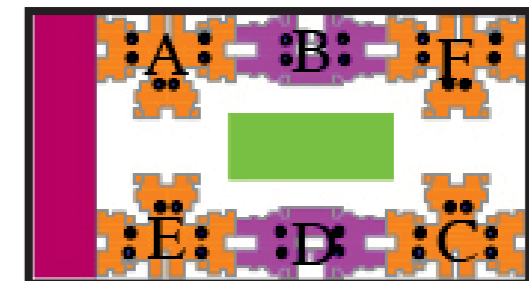

FLOOR PLANS

1 BHK
 ODD FLOORS 1, 3, 5, 7, 9, 11, 16, 18



CASA PRIMIA- (WING- E,G,H,J)
 CASA ELITE- (WING- A,C,E,F,H,J,K,M,O,P,R,T)
 CASA REGALIA- (WING- A,C,E,F)
 CASA PASEO- (WING- D,F,G)

UNIT PLANS



FLOOR PLANS

1 BHK
EVEN FLOORS 2, 4, 6, 10, 12, 15, 17



CASA PRIMIA- (WING- E,G,H,J)
CASA ELITE- (WING- A,C,E,F,H,J,K,M,O,P,R,T)
CASA REGALIA- (WING- A,C,E,F)
CASA PASEO- (WING- D,F,G)

UNIT PLANS



FLOOR PLANS

2 BHK OPTIMA
ODD FLOORS 1, 3, 5, 7, 9, 11, 16, 18

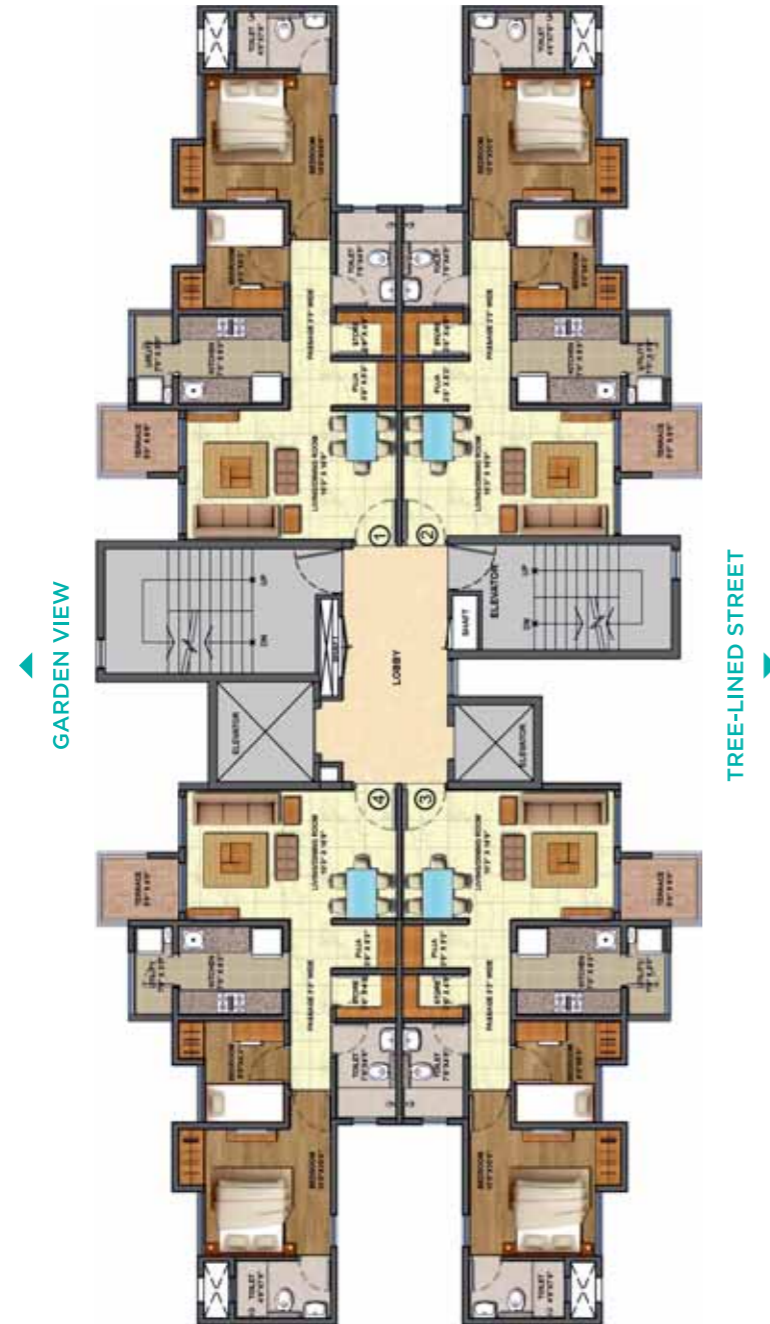

CASA PRIMIA- (WING- F,I)
CASA ELITE- (WING- B,D,G,I,L,N,Q,S)
CASA PASEO- (WING-,E,H)

UNIT PLANS



FLOOR PLANS

2 BHK OPTIMA
EVEN FLOORS 2, 4, 6, 10, 12, 15, 17

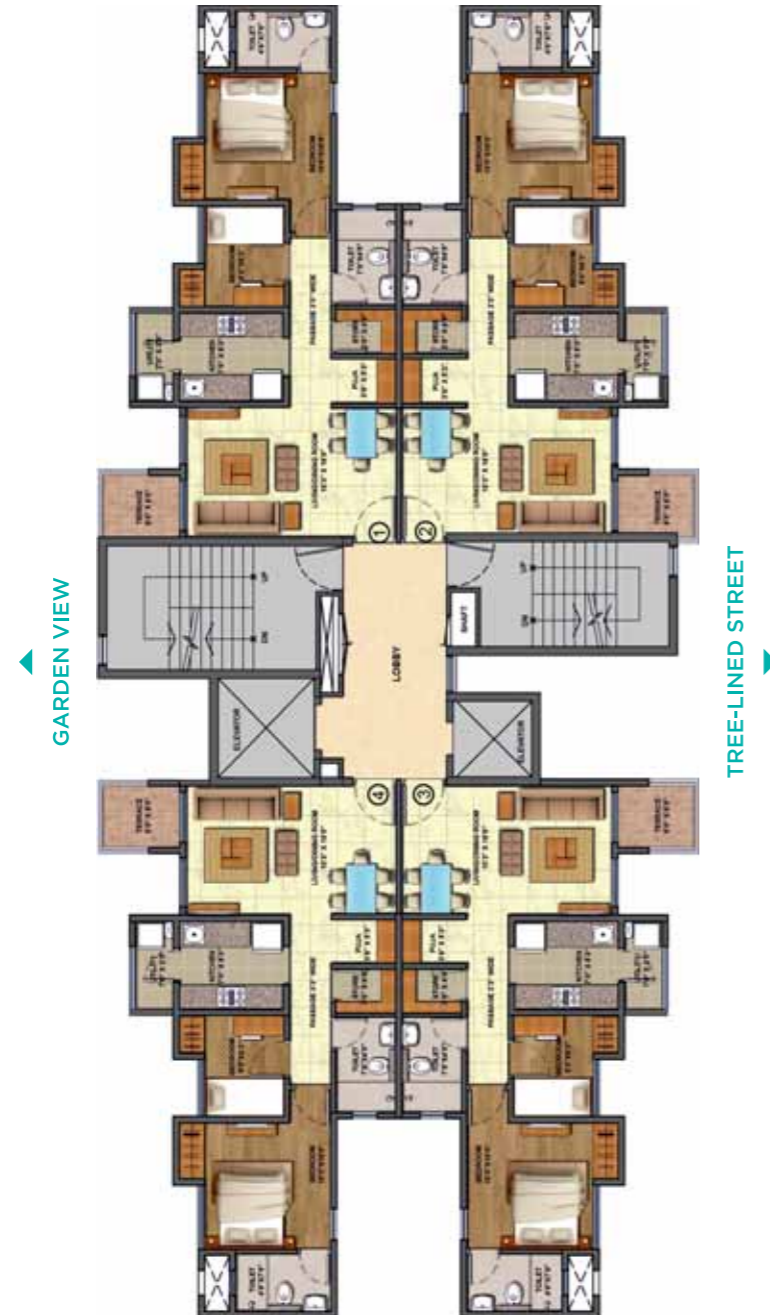

CASA PRIMIA- (WING- F,I)
CASA ELITE- (WING- B,D,G,I,L,N,Q,S)
CASA PASEO- (WING-,E,H)

UNIT PLANS



INTELLIGENT DESIGN AND ELEGANT FINISHES COME TOGETHER TO GIVE YOU THE PERFECT RESIDENCE



INTELLIGENTLY DESIGNED 1 & 2 BED RESIDENCES WITH LUXURY FINISHES

1. Air-conditioned master bedroom with high quality split air-conditioner
2. Spectacular garden, lake or tree-lined street views
3. Marbltal® flooring in living room, dining area and passage
4. Bedrooms with stylish imported wooden flooring, separate wardrobe areas[#]
5. Sundecks with French Windows[#]
6. Kitchen with high-grade granite platform, stainless steel sink, and premium vitrified tiling
7. Bathrooms with Jaquar fittings¹, imported sanitaryware¹ and designer vitrified tiles
8. Provision for telephone, high-speed internet access and digital gaming in each residence
9. Separate utility room
10. Spacious double-height terraces
11. Personal garden and kitchen yard
12. Store room
13. Puja room



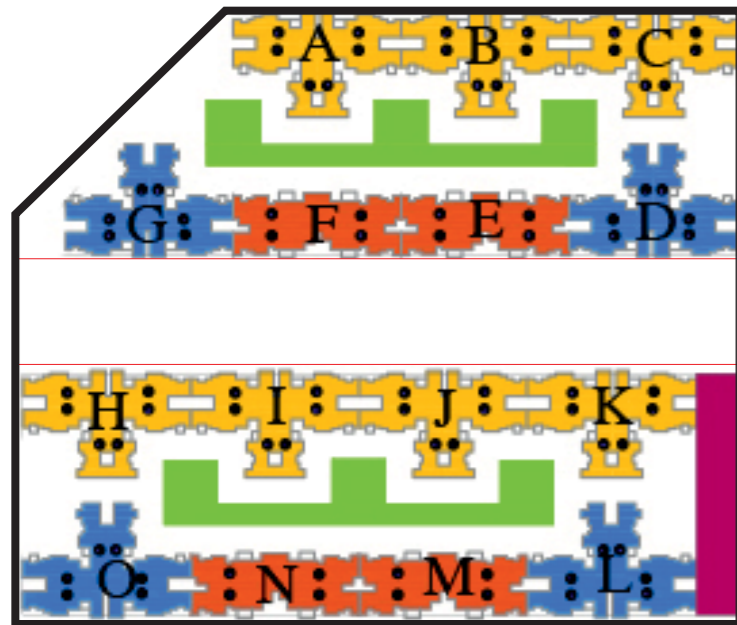

Pt. No. 9, 10, 11, 12, 13 Only available in select residences.

PROJECT PLANS



CASA UNO

LEGEND

-  2 BHK OPTIMA & ULTIMA TYPE 1
-  3 BHK
-  2 BHK OPTIMA & ULTIMA TYPE 2
-  COURTYARD AROUND YOUR HOME WITH PLAY AREA, WALKWAY & SEATING AREA
-  HIGH - STREET SHOPPING & DINING



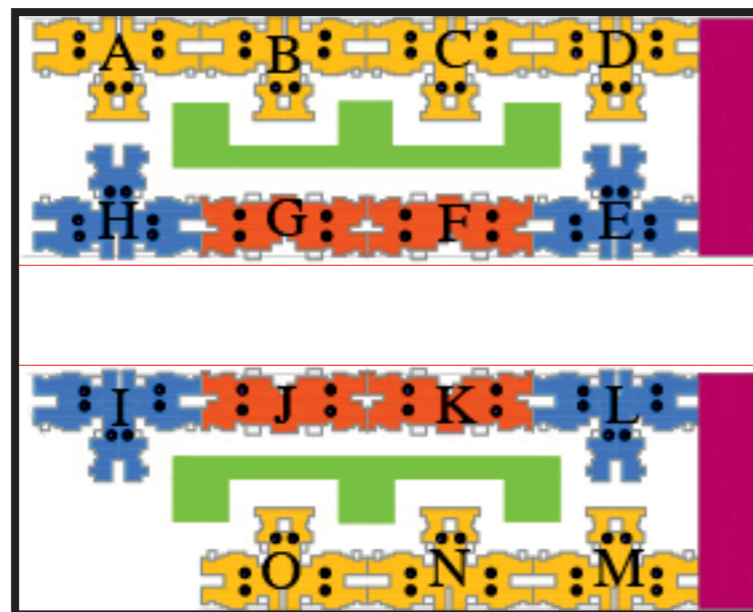

CASA LAKESIDE

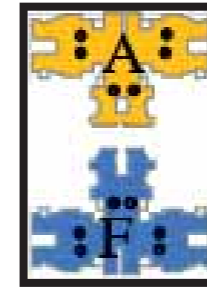

CASA CIELO



LEGEND

-  2 BHK OPTIMA & ULTIMA TYPE 1
-  3 BHK
-  2 BHK OPTIMA & ULTIMA TYPE 2
-  COURTYARD AROUND YOUR HOME WITH PLAY AREA, WALKWAY & SEATING AREA
-  HIGH - STREET SHOPPING & DINING

CASA LAGOONA

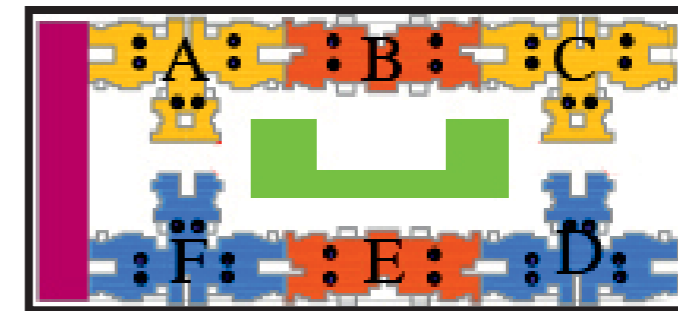

CASA VIENTO

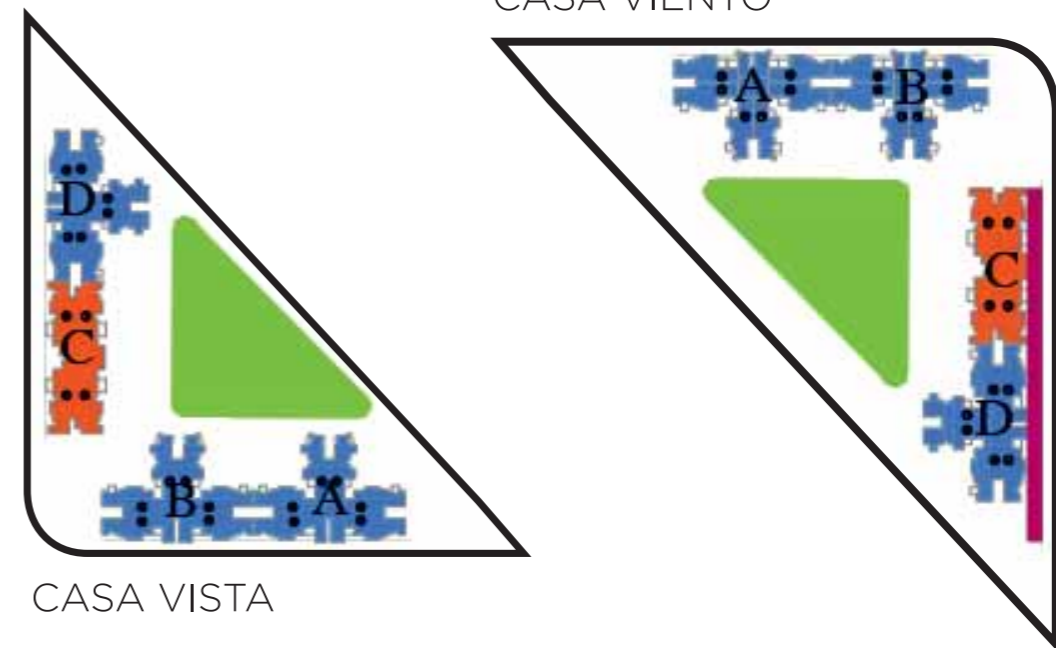

CASA VISTA

FLOOR PLANS

2 BHK OPTIMA, 2 BHK ULTIMA - TYPE 1
 ODD FLOORS 1, 3, 5, 7, 9, 11, 16, 18

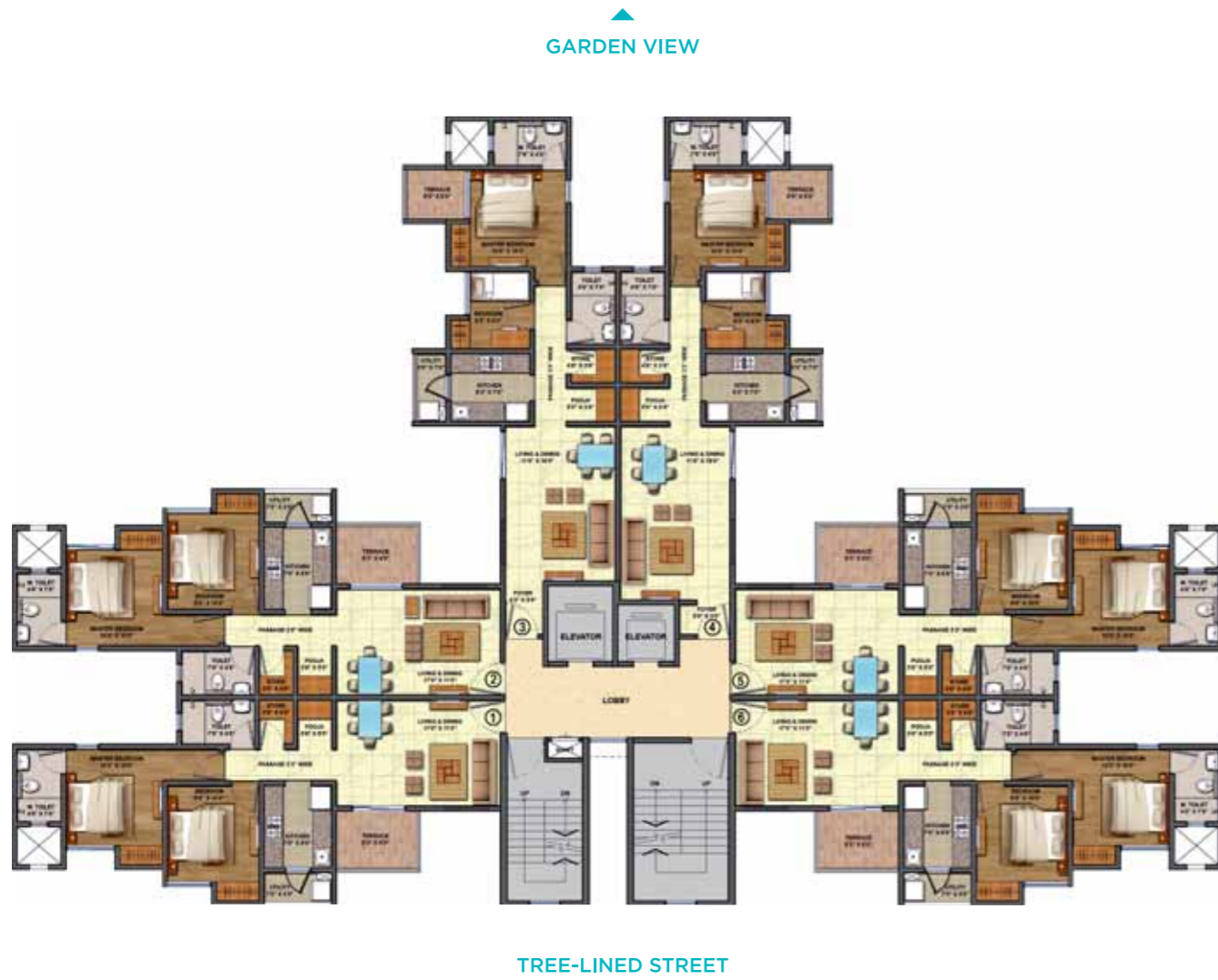

CASA UNO- (WING- L,O)
 CASA VIENTO- (WING- A,B,D)
 CASA VISTA- (WING- A,B,D)
 CASA LAKESIDE- (WING- E,H,L,I)
 CASA CIELO- (WING-F)

UNIT PLANS



FLOOR PLANS

2 BHK OPTIMA, 2 BHK ULTIMA - TYPE 1
EVEN FLOORS 2, 4, 6, 10, 12, 15, 17

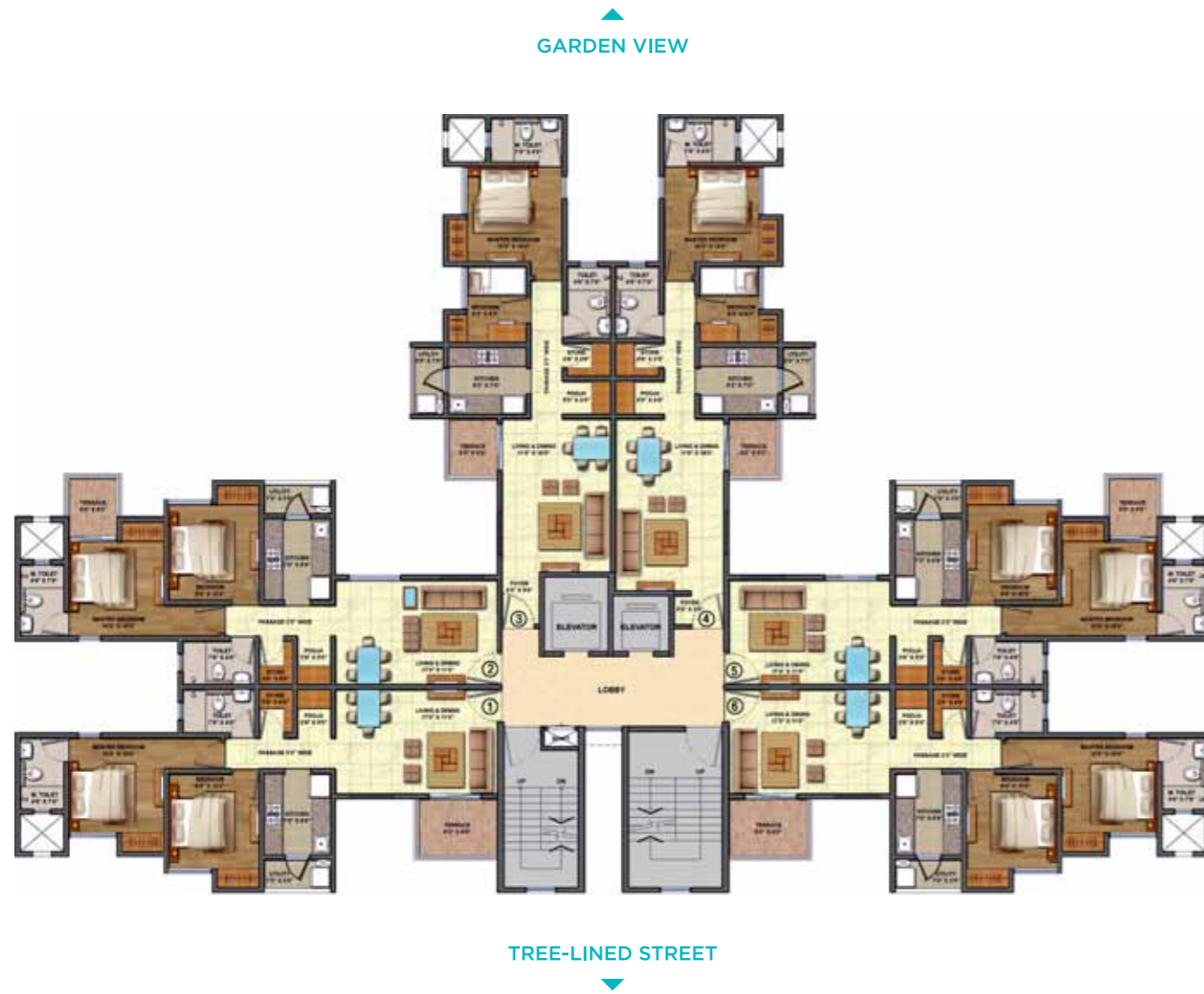

- CASA UNO- (WING- L,O)
- CASA VIENTO- (WING- A,B,D)
- CASA VISTA- (WING- A,B,D)
- CASA LAKESIDE- (WING- E,H,L,I)
- CASA CIELO- (WING-F)

UNIT PLANS



FLOOR PLANS

2 BHK OPTIMA, 2 BHK ULTIMA - TYPE 2
 ODD FLOORS 1, 3, 5, 7, 9, 11, 16, 18

GARDEN VIEW



TREE-LINED STREET

CASA UNO- (WING- I,J,K)
 CASA LAGOONA- (WING- A,C)
 CASA LAKESIDE- (WING- A,B,C,D,M,N,O)
 CASA CIELO- (WING- A)

UNIT PLANS



FLOOR PLANS

2 BHK OPTIMA, 2 BHK ULTIMA - TYPE 2
EVEN FLOORS 2, 4, 6, 10, 12, 15, 17

GARDEN VIEW



TREE-LINED STREET

CASA UNO- (WING- I,J,K)
CASA LAGOONA- (WING- A,C)
CASA LAKESIDE- (WING- A,B,C,D,M,N,O)
CASA CIELO- (WING- A)

UNIT PLANS



FLOOR PLANS

3 BHK OPTIMA
 ODD FLOORS 1, 3, 5, 7, 9, 11, 16, 18

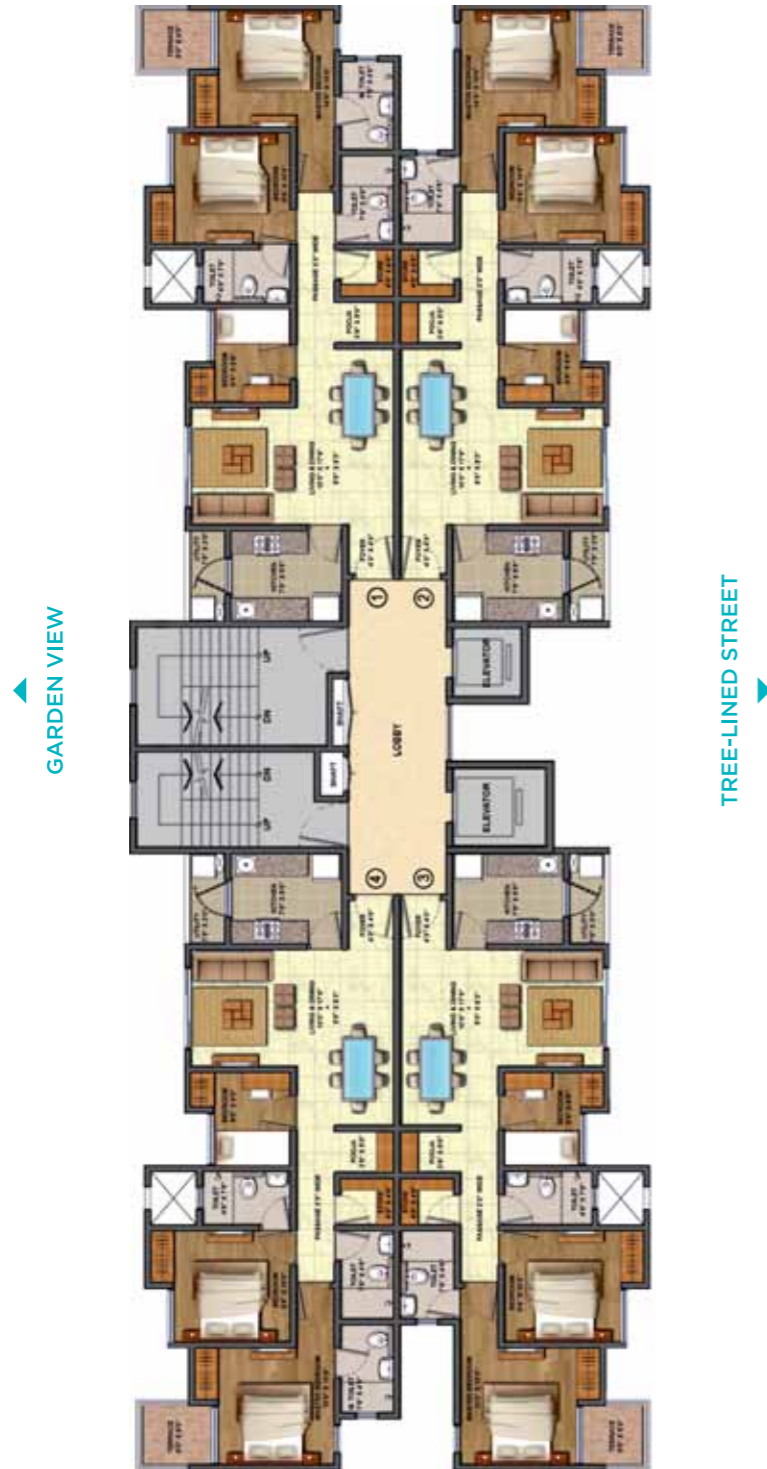

CASA UNO- (WING- M,N)
 CASA LAGOONA- (WING- B,E)
 CASA VIENTO- (WING- C)

CASA VISTA- (WING- C)
 CASA LAKESIDE- (WING- F,G,K,J)

UNIT PLANS



FLOOR PLANS

3 BHK OPTIMA
EVEN FLOORS 2, 4, 6, 10, 12, 15, 17



CASA UNO- (WING- M,N)
CASA LAGOONA- (WING- B,E)
CASA VIENTO- (WING- C)

CASA VISTA- (WING- C)
CASA LAKESIDE- (WING- F,G,K,J)

UNIT PLANS



**EVERY LUXURY YOU CAN THINK OF.
COMING HOME NEVER
FELT THIS GOOD.**

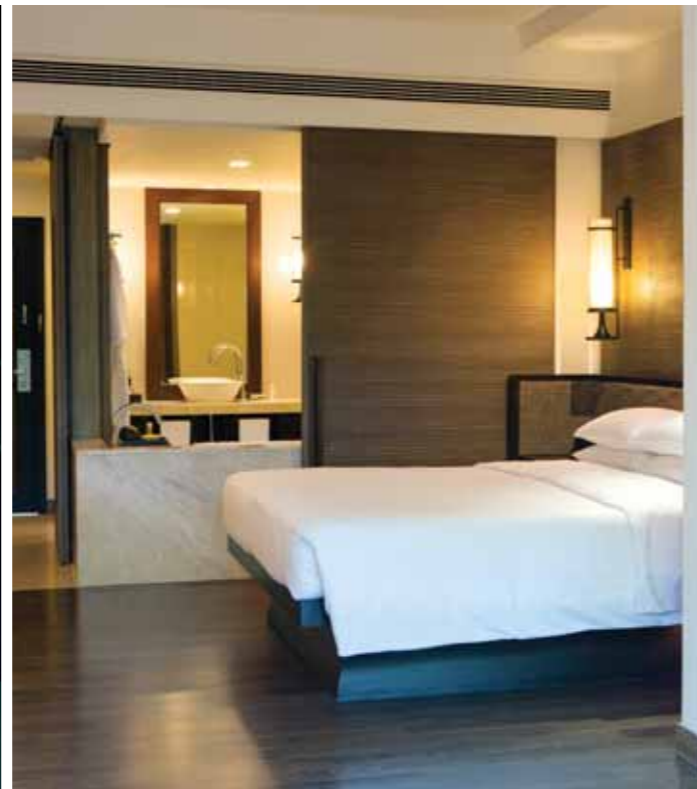

INTELLIGENTLY DESIGNED 2 & 3 BED RESIDENCES WITH LUXURY FINISHES

1. Fully air-conditioned residences³ with high quality split air-conditioner
2. Spectacular garden, lake or tree-lined street views
3. Marbltal® flooring in living room, dining area and passage
4. Bedrooms with stylish imported wooden flooring and separate wardrobe areas[#]
5. Sundecks with French Windows[#]
6. Kitchen with high-grade granite platform, stainless steel sink and premium vitrified tiling
7. Bathrooms with Jaquar fittings¹, imported sanitaryware¹ and designer vitrified tiles
8. Provision for telephone, high-speed internet access and digital gaming in each residence
9. Separate utility room
10. Puja room
11. Spacious double-height terraces
12. Personal garden and kitchen yard
13. Store room
14. Video Door Phone